

# EP PRESS

EPM MODULES FOR FAST MOULD CLAMPING

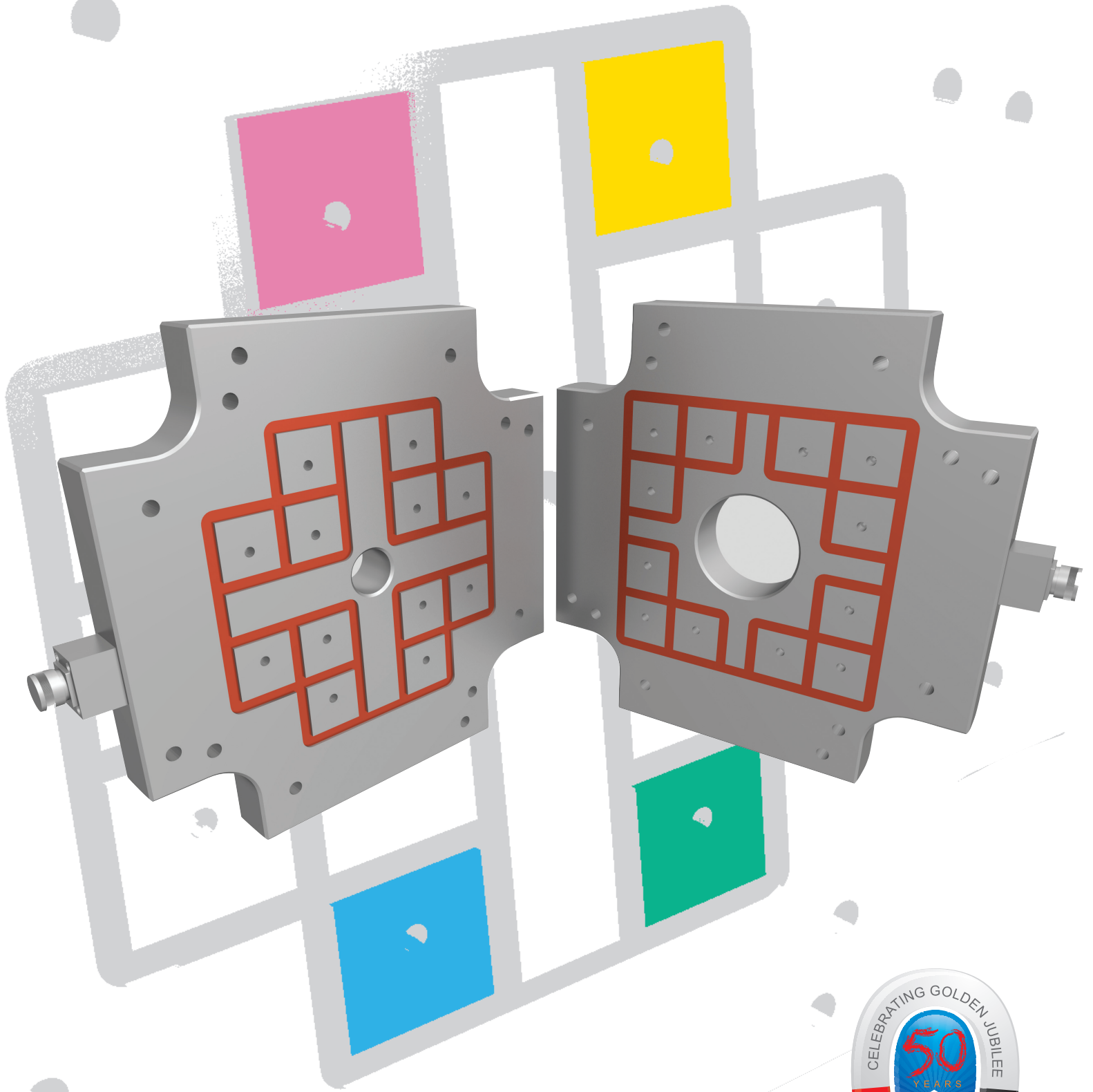

# EP PRESS

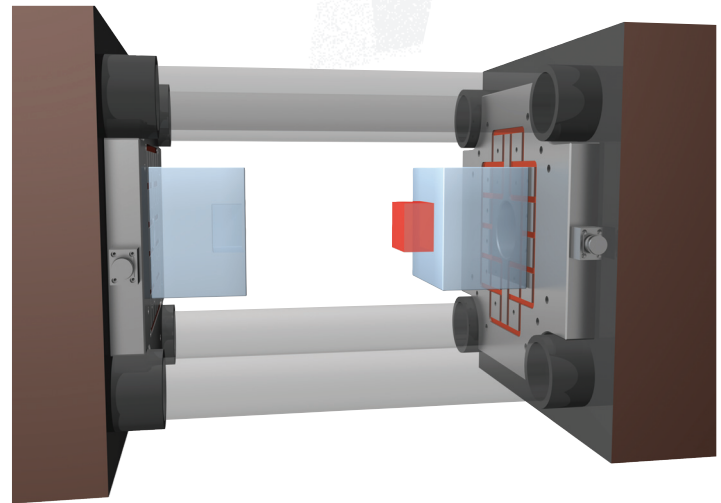

## Features:

- **FMC, Fast Mould Clamping system:** These magnets help in changing the moulds very fast as the time required for clamping the mould is reduced to a few minutes.
- Based on **Electro Permanent Magnet (EPM)** technology, which requires a pulse of electric current to switch ON and then no electric power is required.
- Fail proof holding system of moulds during power failure
- Machined from Solid steel hence structurally very stable.
- **Patent Applied, Mould Displacement Monitoring Circuit:** This revolutionary circuit takes feed back from the magnet to check the displacement of the mould. This technology has been applied for patent. This system has many benefits over the conventional proximity switch type sensors.
- Epoxy is 1.5mm below the surface hence no variation due to heat-up.
- A wide range of pole configurations are available which gives us the flexibility to design the best suited and optimum solution as per customers requirements.

## Application:

- For clamping of moulds in injection molding machines.

POLE CONFIGURATION	5050P	32100P	7070P	7575P
Magnetic Force for each pole	320 kgf	350 kgf	750 kgf	800 kgf
Size of the poles	50x50 mm	32x100 mm	70x70 mm	75x75mm
Thickness of the magnet	50mm	50mm	53mm	53mm
Max working temperature (mold contact face)	120 °C	120 °C	120 °C	120 °C
Hieght of magnetic flux	10 mm	10 mm	15 mm	15mm
Standard voltages	200/230/400/440/480 VAC, 50/60 Hz			
Electrical input	15kVA (220V single phase) / 25kVA (380V two phase) / 32 kVA (480V)			
Fixing holes and locating ring	EUROMAP / SPI / JIS			

## Available for all Platen sizes as per customers requirement

- Due to continuous upgradation in design there could be changes in specifications.
- Other Pole configuration on request.



### EAST COAST MAGNETS PRIVATE LIMITED 100% EOU

44/1/6, Phase 1, I.D.A. Jeedimetla, Hyderabad - 55, India  
Ph.: (91-40) 2309 8262 • Fax: (91-40) 2309 8261  
E-mail: info@sardamagnets.com  
Website: www.sardamagnets.com

### EAST COAST ENTERPRISERS LIMITED

33, Brabourne Road, Kolkata - 01, India  
Ph.: (91-33) 2242 1796 • Fax: (91-33) 2242 6568  
E-mail: info@sardamagnets.com  
Website: www.sardamagnets.com